

Fifth Nordic Conference on Adult Learning



UNIVERSITY OF ICELAND

Reykjavík Iceland
5-6. March 2013
University of Iceland
School of Education
Programme on Adult learning

Welcome

Dear colleague

Welcome to Iceland, welcome to the University of Iceland; School of Education, and welcome to the Fifth Nordic Conference on Adult Learning.

During the last seven years I have been fortunate to participate in various Nordic conversations on Adult Learning. This has been a most enjoyable and fascinating learning experience and a time for personal growth.

It is therefore I feel honoured and happy to welcome you to this event.

In the Nordic countries we often say we have a culture of discussion, and I am sure many of us agree that we have often participated in inspiring discussions with colleagues from our neighbouring countries.

It seems to me that the reasons these Nordic conversations are so useful is partly that we are so much alike, that we understand each other (obviously as we all spoke Icelandic a few centuries ago) and partly that we are different enough to be able to learn from each other.

Of course Nordic connections historically reach further than to the five Nordic countries.

We have deep, but very poorly documented connections to the northern and western parts of the British Isles, and early connections to Newfoundland. Therefore it is even more encouraging to have colleagues from these parts of the north participating in this conference.

During the last conference we were encouraged to stimulate discussions and get practitioners to participate in this conference, which has usually been dominated by academics. I am happy to see that about half the participants are so called “practitioners”

We are sure that by acknowledging this suggestion we have managed to create a forum for interesting discussions, inspiring conversations and a useful exchange of ideas and practices.

There is a suitable number of interesting papers to discuss and ample time to converse each theme. I am sure that we will all have an opportunity to contribute and will return home much richer than we came.

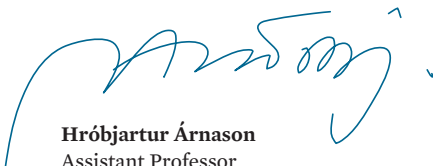

Hróbjartur Arnason

Assistant Professor

Director of the Master's programme for Adult Learning
School of Education, University of Iceland.

Program

4TH MARCH MONDAY EVENING

18:00-19:00 Registration and informal get together in Venue:
The Faculty of Education

5TH MARCH TUESDAY

8:30 Registration for people who arrived late
9:00 Welcome and practical information (in H207)
9:20 Keynote 1: Andreas Fejes:
The role of theory in research on the education
and learning of adults
10:10 Coffee break
10:30 Parallel Session 1 (Session A in H001 & Session B in H206)
12:00 Lunch
13:00 Parallel Session 2 (Session C in H001 & Session D in H206)
14:30 Coffee
15:00 -16:30 NVL Symposium (In H207)
16:30 End of working day
18:00 City walk with professional guide to Conference Dinner.
Meeting point in Reykjavik Harbour (place to be announced)
19:00 Conference Dinner (Íðnó)

6TH MARCH WEDNESDAY

9:00 Interview and discussions
9:20 Keynote 2 (in H207): Ingibjörg Elsa Guðmundsdóttir
How can research and theory support the practice of adult educa-
tion? (Working Title)
10:10 Coffee break
10:30 Parallel Session 4 (Session E in H001 & Session F in H206)
12:00 Lunch
13:00 Parallel Session 5 (Session G in H001 and Session H in H206)
14:30 Coffee
15:00 Fishbowl discussion, summing up of conference (in H207).
Bjarne Wahlgren will sum up and lead the fishbowl discussion
16:30 Conference closing

Meeting points of theory and practice

Parallel Session 1 Tuesday 10.30 - 12.00

Session A
in H-001

Blended learning in vocational training

Henriette Duch (HEDU), Lene Mark, Hanne Wacher Kjaergaard

Problem based learning as a cultural tool for health and safety learning in a multi-national company

Søren Henrik Adam, Eva Petersson Brooks

Intersubjectivity in entrepreneurial education

Timo Nevalainen

Session B
in H-206

Erosion of theory and practice in adult education?

Anja Heikkinen

Cogenerative learning and research – heterogeneity and reflective leadership

Robert Skaresund

Parallel Session 2 Tuesday 13.00 - 14.30

Session C
in H-001

How can dialogue enhance the learning experience of older adults (45+) in higher education?

Chris McAllister, Grace Poulter

Learning in later life and the U3A movement in Norway

Sigvart Tøsse

Session D
in H-206

How can active citizenship be learned?

Annika Turunen

The next step?

Bruce Spencer & Jennifer Kelly

Why LLL should be moved to the central stage of the system of education

Jón Torfi Jónasson

Parallel Session 3 Wednesday 10.30 - 12.00

Session E
in H-001

Managing learning in management
Christian Tang Lystbæk

**Producing subjects in beauty school advertisement –
a question of gendered knowledge and consumerism**
Eleonor Bredlöv

**Finnish teachers' experiences of internal and
external evaluation as a tool for development**
Päivi Atjonen

Session F
in H-206

Teaching judging and judging teaching in teacher education
Birthe Lund & Lars Lindhart,

**Changes in teaching habits reported by folk high school teachers
after having the opportunity to watch themselves teach on video**
Eva-Marie Harlin

How and why teachers try to make students think
Jonna Lappalainen

Parallel Session 4 Wednesday 13.00 - 14.30

Session G
in H-001

From working life into higher education
Per Andersson

**Job training and developing further competences for
workers in elementary schools other than teachers**
Hidur Betty Kristjánsdóttir & Valgeir B. Magnússon

Session H
in H-206

Can distance education support rural development
Hróbjartur Árnason

Adult education and social capital in local communities
Palle Damkjær Rasmussen

Educating for decolonization: Interculturality in the Andes
Robert Aman

Maps

Basement

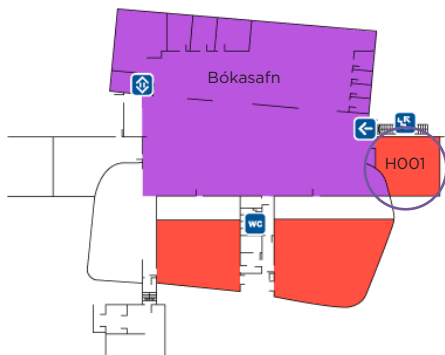

Stakkahlíð, kjallari

2nd floor

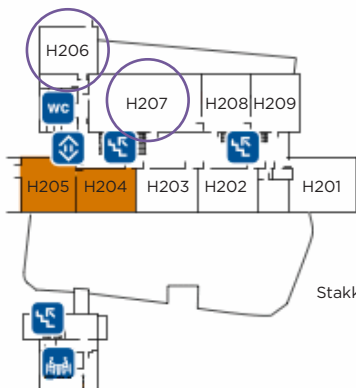

Stakkahlíð, 2. hæð

Lunch

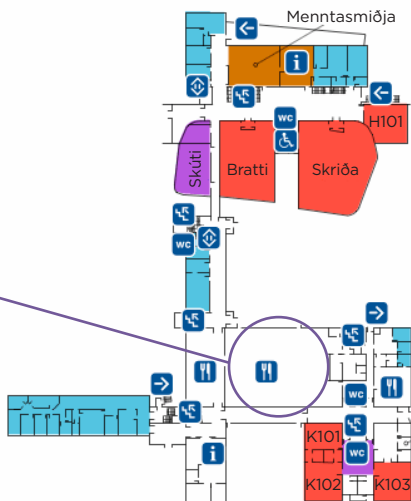

Bóksala

Stakkahlíð, 1. hæð

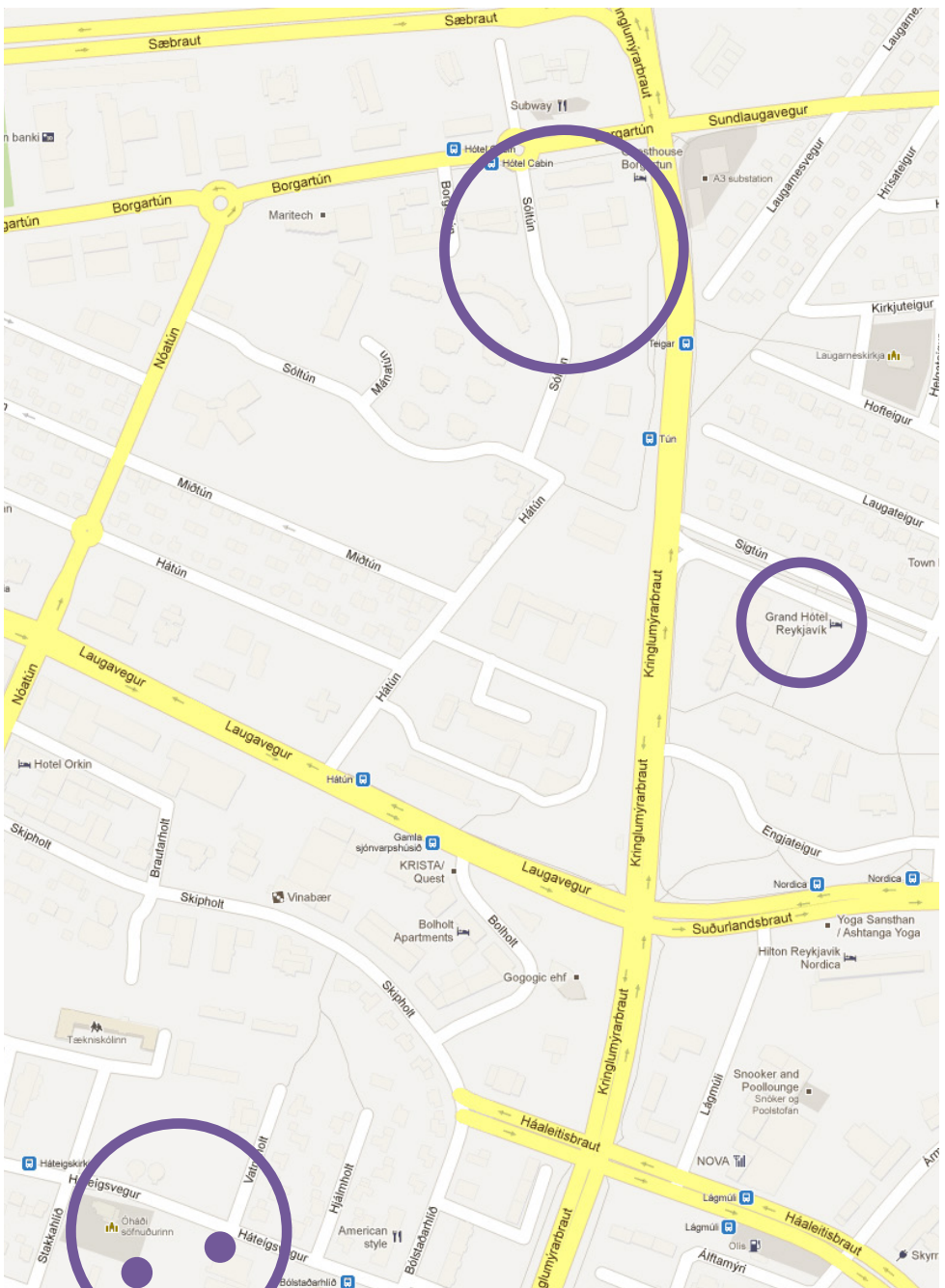

Informal get together

Monday 18-19

RESTAURANTS CLOSE TO VENUE:

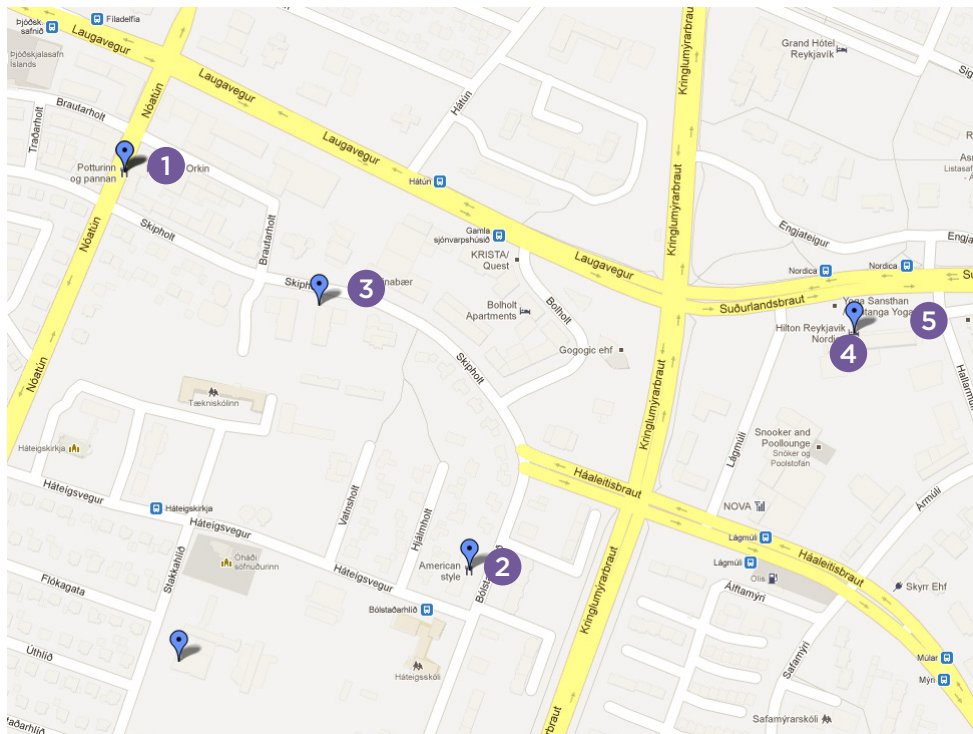

- 1 **Potturinn og pannan** Good Icelandic ingredients, buffet
- 2 **American Style** Hamburger
- 3 **Pítan** Pita with meat, fish or falaffel
- 4 **Vox** in Hotel Hilton Nordica
- 5 on Suðurlandsbraut: East of Hotel Hilton, many Asian restaurants

Many more interesting restaurants downtown. e.g.

Fishmarket rather expensive

Grillmarket rather expensive

Icelandic Fish and Chips reasonable price

Sægreifinn reasonable price

Marina newest hip and cool bar and hang out

Social program

Tuesday evening



A 18.00-19.00
At the harbor

Culture and history walk Reykjavik downtown

Meet at “Mýrin” in the harbor and take a short walk through old downtown Reykjavik with a guide – interesting stories and sights -. The tour ends at the Iðnó Restaurant for the conference dinner.

B 19.00
Iðnó

Conference dinner Restaurant Iðnó

For those who have not registered yet please let us know if you will be attending the dinner.

Participants

NAME	PLACE OF WORK	EMAIL	COUNTRY
Andreas Fejes	Linköping University	andreas.fejes@liu.se	Sweden
Anette Lund Follestad	Senter for voksnes læring i Hamarregionen	lucie.furulund@hedmark.org	Norway
Anja Heikkinen	School of Education / University of Tampere	anja.heikkinen@uta.fi	Finland
Ann Christin Jacob	Senter for voksnes læring i Hamarregionen	lucie.furulund@hedmark.org	Norway
Annika Turunen	Adult Education, Åbo Akademi University	aturunen@abo.fi	Finland
Antra Carlsen	Nordic Network for Adult Learning	antra.carlsen@vox.no	Norway
Berglind Axelsdóttir	Háskóli Íslands	berglind@fsn.is	Iceland
Birthe Lund	Institut for læring og filosofi, Aalborg Universitet	bl@learning.aau.dk	Denmark
Bjarne Bo Wahlgren	Århus Universitet	wahlgren@dpu.dk	Sweden
Bruce Spencer	Athabasca University	bruce@athabascau.ca	Canada
Christian Lystbæk	Aarhus University	christianl@hih.au.dk	Denmark
Eleonor Bredlöf	Linköping University	eleonor.bredlov@liu.se	Sweden
Eva Andersson	Department for Education and Special Education	eva.andersson@ped.gu.se	Sweden
Eva Daae Kversøy	Hospitality of Mind	lucie.furulund@hedmark.org	Norway
Eva-Marie Harlin	Linköpings universitet/IBL	eva-marie.harlin@liu.se	Sweden
Gerd Karin Nylund	Tertiary professional school inn Hamar	lucie.furulund@hedmark.org	Norway
Gerd Stølen	Department of education	gerd.stolen@uit.no	Norway
Grace Poulter	Glasgow Caledonian University	Grace.Poulter@gcu.ac.uk	United Kingdom
Guðríður Pálmarsdóttir	Hrafnista	gurryelfa@yahoo.co.uk	Iceland
Halla Valgeirsdóttir	Fræðslumiðstöð atvinnulífsins	halla@frae.is	Iceland
Henriette Duch	VIA University College	hedu@viauc.dk	Denmark
Henrik Adam	Aalborg University / Center for Design Learning and Innovation	sha@learning.aau.dk	Denmark
Hildur Betty Kristjansdóttir	SÍMEY	betty@simey.is	Iceland
Hróbjartur Árnason	School of Education, University of Iceland	hrobjartur@hi.is	Iceland
Inger-Ann Hanssen	University of Tromsø	inger.a.hanssen@uit.no	Norway
Ingibjörg Elsa Guðmundsdóttir	Education and Training Service Centre	ingibjorg@frae.is	Iceland
Ingibjörg Gísladóttir	City of Reykjavík – Dep of Education and Leisure	ingibjorg.gisladottir@reykjavik.is	Iceland
Janca Molthe Van Doorn	Senter for voksnes læring i Hamarregionen	lucie.furulund@hedmark.org	Norway

NAME	PLACE OF WORK	EMAIL	COUNTRY
Jan-Erik Perneman	Högskolan Väst/UNiversity West	perneman@gmail.com	Sweden
Jennifer Kelly	University of Alberta	jennifer.kelly@ualberta.ca	Canada
Jonna Lappalainen	Centrum för praktisk kunskap	jonna.lappalainen@sh.se	Sweden
Jón Torfi Jónasson	School of Education, University of Iceland	jtj@hi.is	Iceland
Karl Gränz	University of Iceland	karlgranz@hotmail.com	Iceland
Kristín Lára Ólafsdóttir	Landspítali, University Hospital	klome@internet.is	Iceland
Lucie Furulund	Senter for voksnes læring i Hamarregionen	lucie.furulund@hedmark.org	Norway
María Marquard	Nordic Network for Adult Learning, AU.dk	marq@dpu.dk	Denmark
Marianne Sempler	AiR - Nasjonalt kompetansesenter	msempler@online.no	Norway
Marit Frederiksen Jordet	Senter for voksnes læring i Hamarregionen	lucie.furulund@hedmark.org	Norway
Paivi Atjonen	University of Eastern Finland	paivi.atjonen@uef.fi	Finland
Palle Rasmussen	Department of Learning and Philosophy, Aalborg University	palleras@learning.aau.dk	Denmark
Per Andersson	Linköping University	per.andersson@liu.se	Sweden
Ragnhildur Bolladóttir	Framvegis miðstöð símenntunar	ragnhildur@framvegis.is	Iceland
Robert Aman	Linköping University	robert.aman@liu.se	Sweden
Robert Skaresund	Centre of Work-integrated Learning and Pedagogical development	robert.skaresund@gmail.com	Sweden
Sigrún Kristín Magnúsdóttir	Arbeidslivets opplæringscenter/NVL	sigrunkri@frae.is	Iceland
Sigvart Tøsse	Departement of Adult Learning and Councelling, Norwegian University of Science and Technology	sigvart.tosse@svt.ntnu.no	Norway
Sólveig Lilja Snæbjörnsdóttir	VR	solveig@vr.is	Iceland
Sylvia Tutzauer Lindqvist	Swedish National Agency for Education	sylvia.lindqvist@skolverket.se	Sweden
Særún Ástþórsdóttir	Miðstöð símenntunar á Suðurnesjum	saerun@mss.is	Iceland
Timo Nevalainen	University of Tampere	timo.nevalainen@uta.fi	Finland
Toril Dale	AiR - Nasjonalt kompetansesenter	toril.dale@air.no	Norway
Valgeir Magnússon	SÍMEY	valgeir@simey.is	Iceland
Vibe Aarkrog	Århus Universitet	vika@dpu.dk	Denmark
Vigdís Asmundsdóttir	Framvegis	vigdis@framvegis.is	Iceland

Organizors



UNIVERSITY OF ICELAND

University of Iceland
School of Education,

Masters Programme for Adult Learning

Contact person:

Hróbjartur Árnason

v/ Stakkahlíð
105 Reykjavík
Iceland

Office telephone: +354 5255393 / **mobile:** +354 8608046 / **mail:** hrobjartur@hi.is

GESTAMÓTTAKAN
YOUR HOST IN ICELAND



The Conference bureau

Your Host in Iceland – Gestamottakan

Kirkjutorg 6
101 Reykjavík

Tel.: (+354) 551 1730 / **mobile:** (+354) 692 1730 / **mail:** yourhost@yourhost.is

Special thanks to to colleagues from AiR – National Center in Norway for their support and cooperation in the didactical organisation of the „Meeting points between theory and practice“ and for facilitating the sessions:

The Parallel Sessions 1 - 4: – “Meeting points of theory and practice” were developed in cooperation with The National Centre for occupational rehabilitation (NCOR) in Norway. The Centre is a leading actor in large scale participatory learning arenas and networks as a vehicle for change. This is done by bringing people together beyond the boundaries of organizations and disciplines. The aim is to achieve knowledge creation that can lead to/stimulate workplace innovation for practitioners and researches within their field.

The parallel sessions are facilitated by Marianne Sempler, senior consultant in pedagogy (NCOR) and Toril Dale, director of network and innovation (NCOR). For more information: www.arbeidoghelse.no.

